



PASSION CREATES INNOVATION

# WE TRANSFORM VISIONS INTO PLASTIC SOLUTIONS

Investors Presentation Q3 2020

Winter 2020/2021  
(Virtual meetings)





# POLYTEC GROUP AT A GLANCE

- Leading developer and manufacturer of high-quality lightweight plastic components
- Solution provider for the Automotive & Non-Automotive-Industry



**627.1**

EUR m sales  
2019 FY

**605.6**

EUR m balance sheet total  
(as of 31 December 2019)

**32.6**

EUR m EBIT  
2019 FY

**3,851**

Employees (incl. leasing personnel)  
(FTE, as of 30 September 2020)

# BUSINESS MODEL



“INDUSTRIAL Division”  
Separated from December 2020

## POLYTEC PLASTICS

### CORE COMPETENCIES:

- 2k injection moulding
- Multi-component injection moulding
- WIT (water injection technology)
- GIT (gas injection technology)
- PIT (projectile injection technology)
- In-Mould-Decoration
- Injection-Moulding-Compounding
- Testing (e.g. Engine test stand)
- Tool making



1,370\*

## POLYTEC COMPOSITES

### CORE COMPETENCIES:

- Production of glass fibre SMC
- Production of carbon fibre SMC
- SMC/LFT/GMT compression moulding
- Hybrid compression moulding (LWRT)
- Wet pressing
- In-Mould-Coating
- Class-A paint coating



1,143

## POLYTEC CAR STYLING

### CORE COMPETENCIES:

- PUR RRIM
- PUR RRIM Lightweight
- PUR rigid
- PUR semi-rigid
- Blow moulding
- Processing of metal & premium steel
- Tool making
- Class-A paint coating
- Just-in-Sequence-Delivery



1,142

## POLYTEC INDUSTRIAL

### CORE COMPETENCIES:

- PUR-processing (moulding parts)
- PUR spraying
- PUR casting
- PUR foaming
- Mechanical engineering
- (multi-component dosing system)

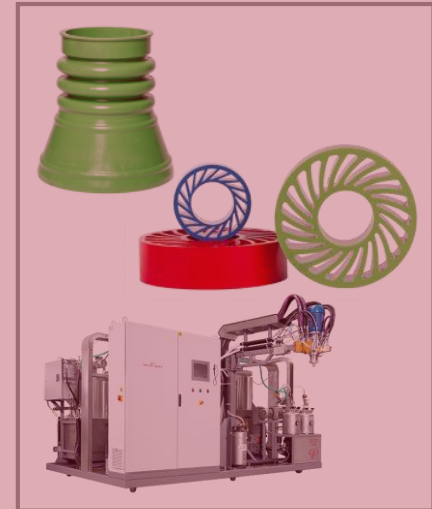

128

In FTE, incl. leasing personnel, as of 30 September 2020

# SALES SPLIT BY MARKET AREA & CUSTOMER PORTFOLIO

Q1-Q3 2020

Group sales:  
EUR m 379.4

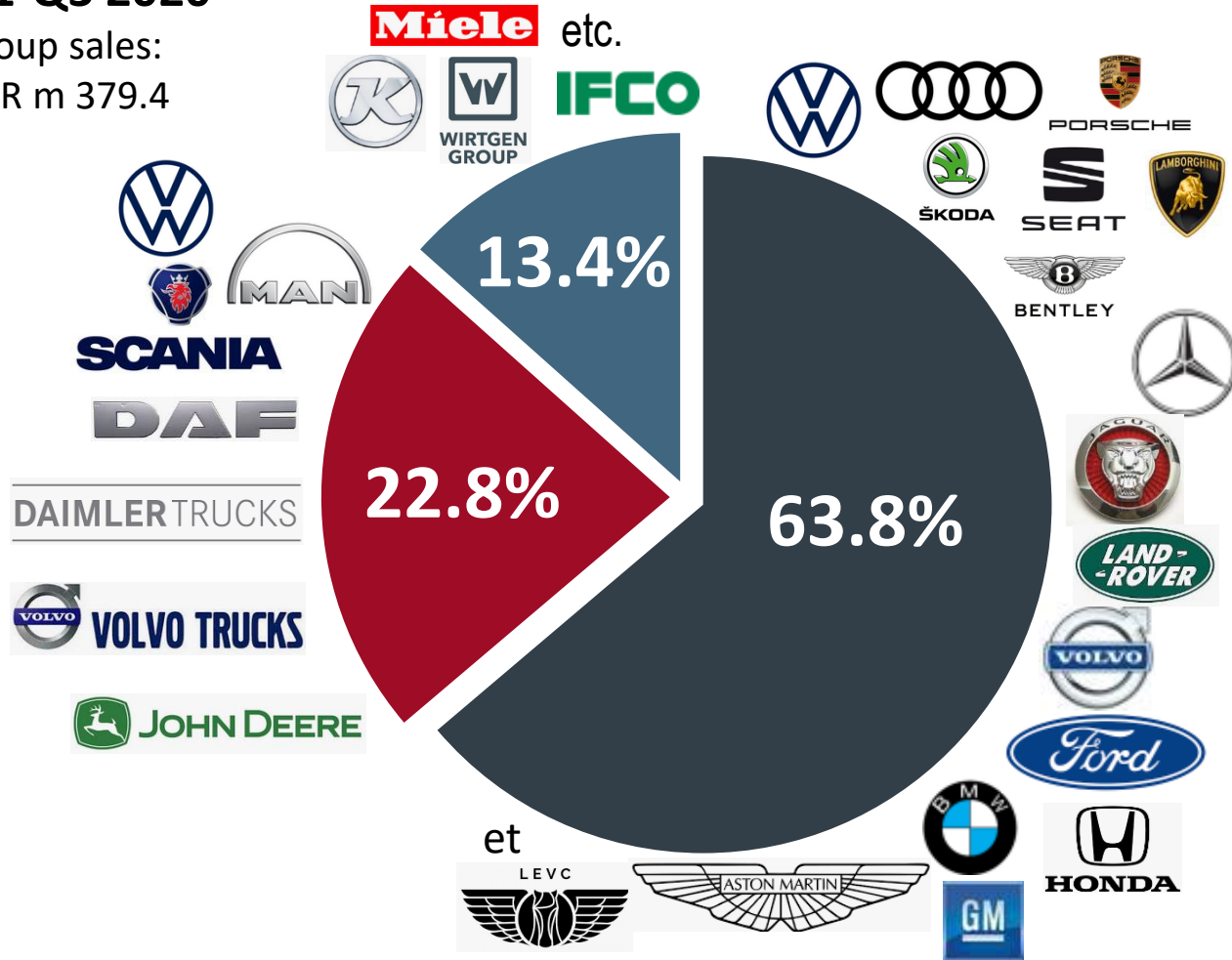

- Passenger Cars & Light Commercial Cars
- Commercial Cars
- Smart Plastics & Industrial Applications

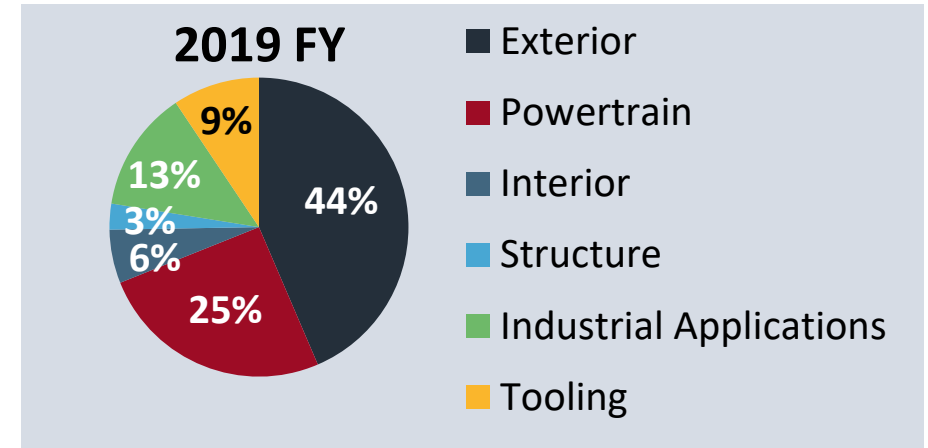

# GLOBAL NEW PASSENGER CAR REGISTRATIONS – JAN-NOV 2020

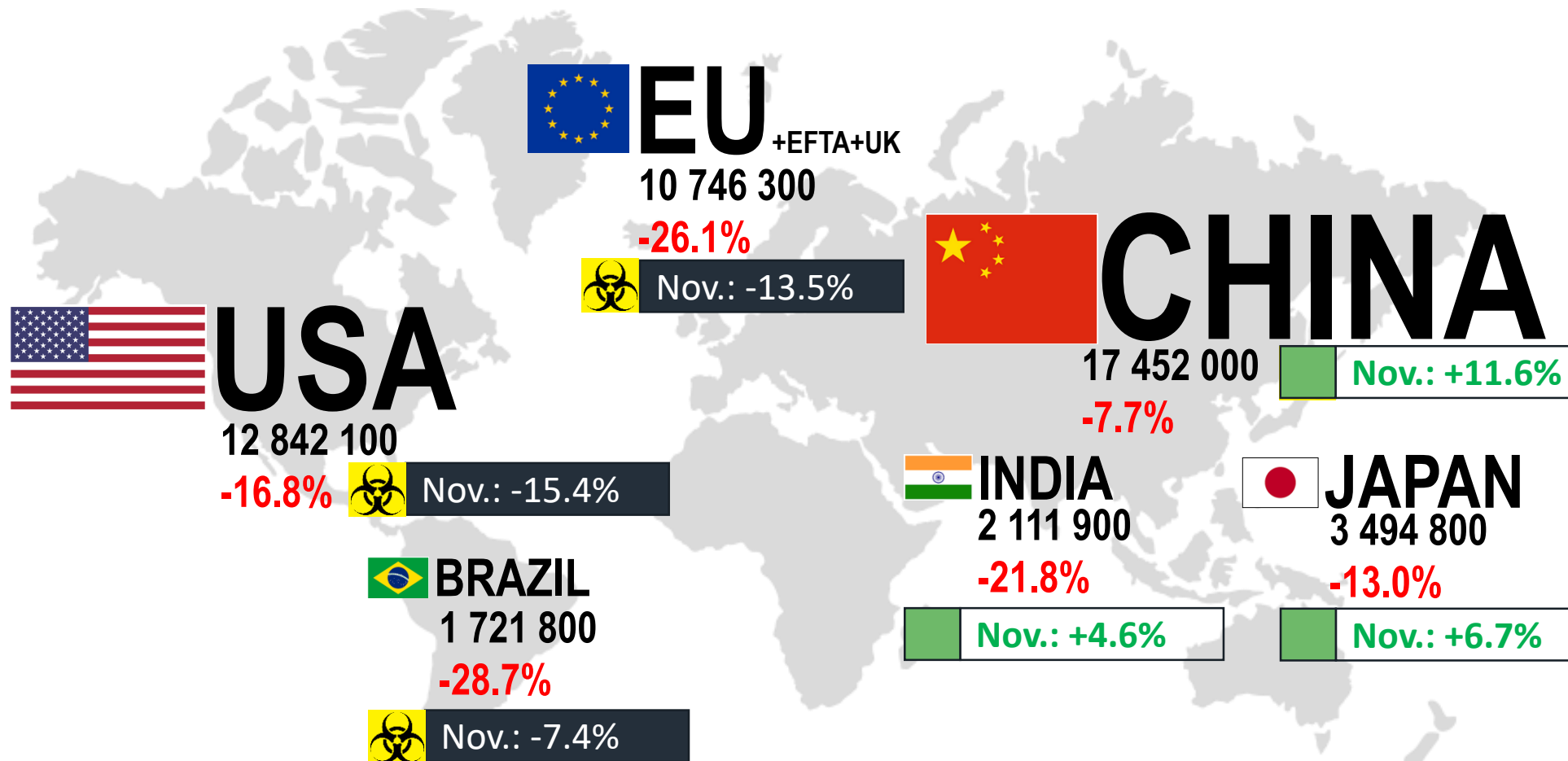

 COVID-19 impact

Explanation: Percentages compared to the same period of the previous year

Source: VDA

# NEW PASSENGER CAR REGISTRATIONS IN EUROPE

## JAN-NOV 2020 (COMPARED TO THE SAME PERIOD OF THE PREVIOUS YEAR)

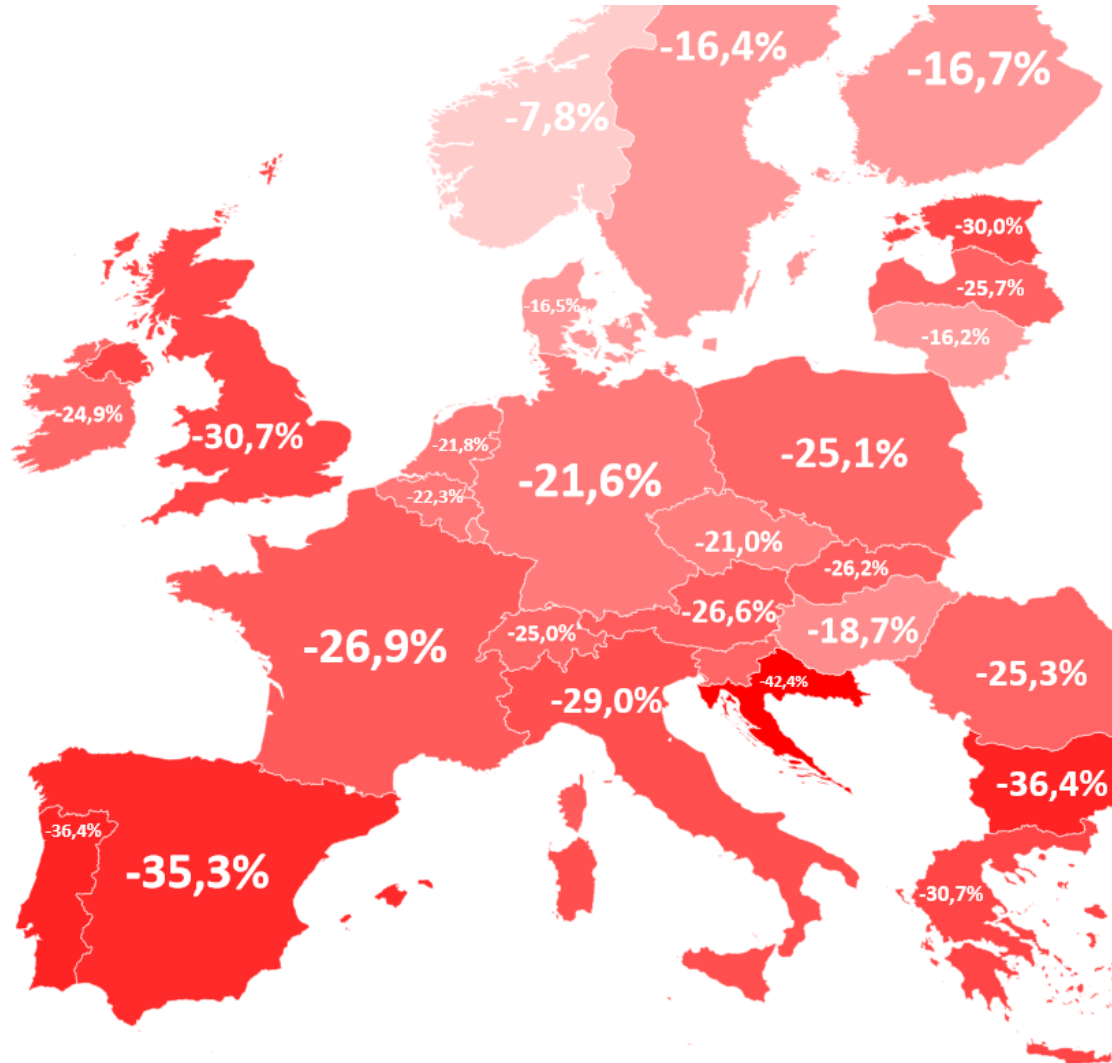

**EU: 8 911 131 (-3 051 928) -25.5%**

- In **November 2020**, new car registrations in the **European Union fell by 12.0%** to **897,692 units**, as several European governments introduced new measures to contain the second wave of the COVID-19 pandemic.
- **November performance of EU's largest markets: Germany -3.0%, Italy -8.3%, Spain -18.7%, France -27.0% and UK -27.4%**
- **„Big 5“ YTD**
  1. GE: 2 606 284 -21.6%
  2. UK: 1 498 382 -30.7%
  3. FR: 1 463 795 -26.9%
  4. IT: 1 261 802 -29.0%
  5. ES: 745 369 -35.3%

# NEW PASSENGER CAR REGISTRATIONS IN THE EU BY FUEL TYPE 2017 – Q3 2020

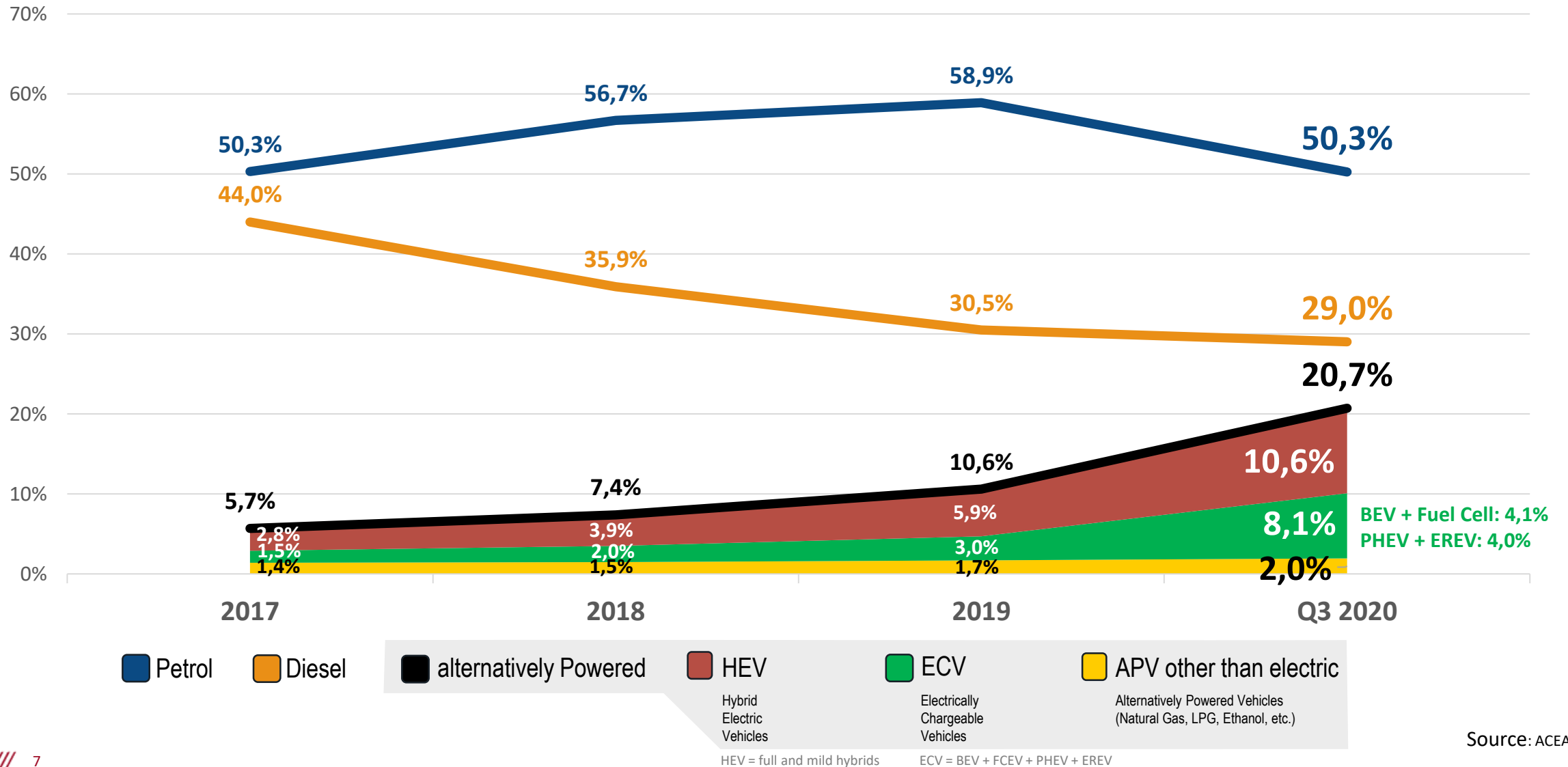

# POLYTEC SOLUTION FORCE

**WE TRANSFORM VISIONS INTO PLASTIC SOLUTIONS**

**Concentration of the extensive expertise available throughout the POLYTEC GROUP:**

- **Technological and manufacturing competences** at its various plant locations
- High degree of **value added**
- **Innovative strengths** in the product and material development fields
- **Profound understanding of the market**

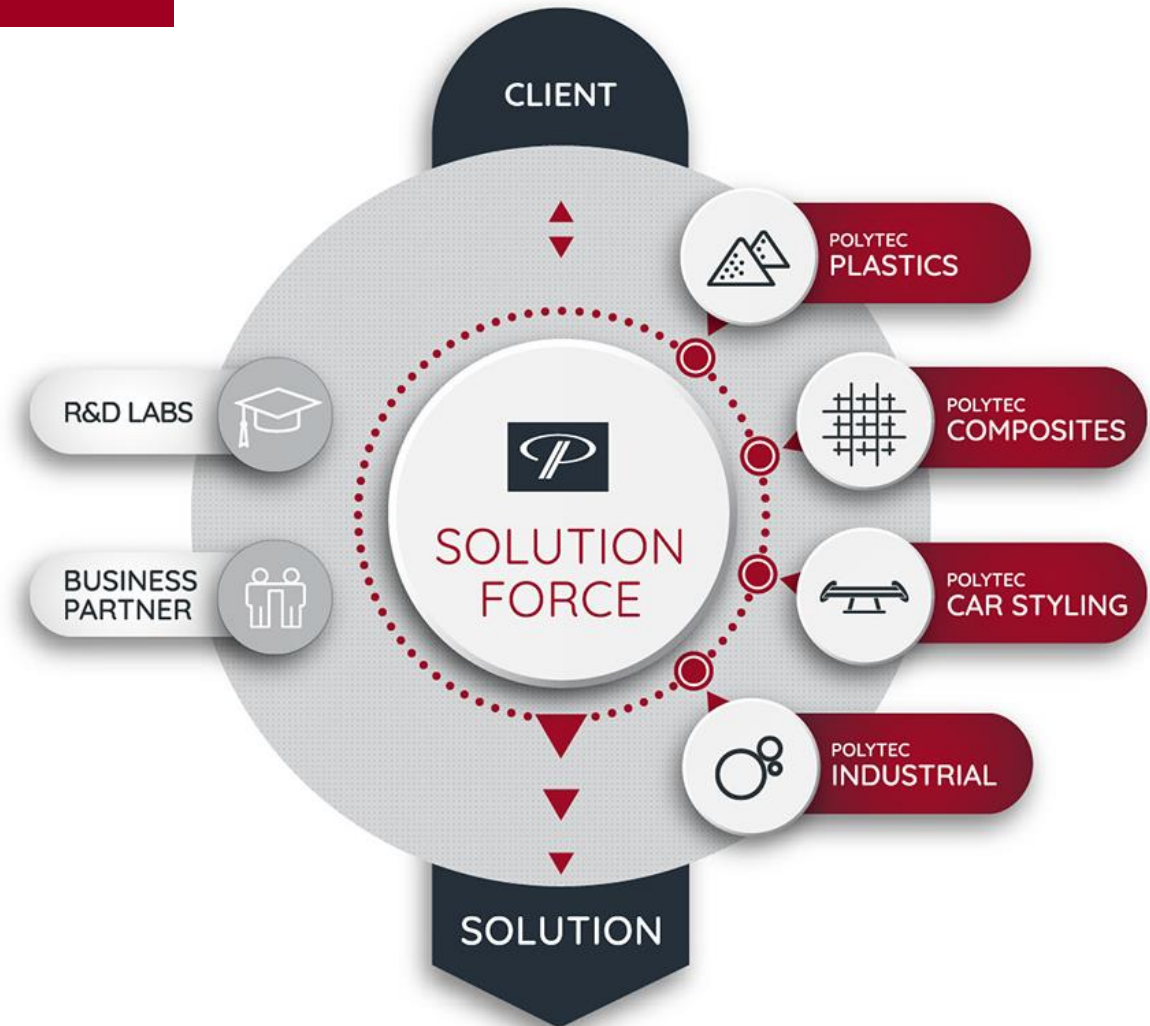



# PRODUCT LINES

1

NEW MOBILITY  
&  
STRUCTURAL  
INNOVATIONS



3

TRUCK, BUS &  
AGRICULTURAL  
APPLICATIONS

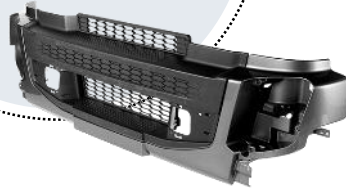

5

POWERTRAIN  
SOLUTIONS



7

UNDERBODY  
SOLUTIONS

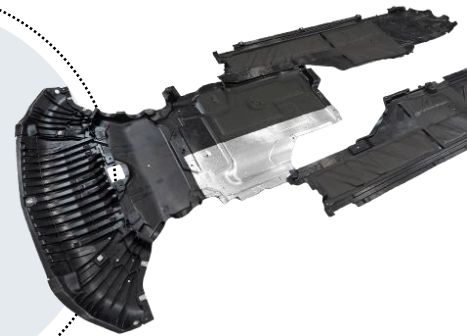

2

SMART PLASTIC  
APPLICATIONS



4

PAINTED  
EXTERIOR  
> SPECIAL SERIES



6

POWERTRAIN  
ACOUSTICS



8

INDUSTRIAL  
APPLICATIONS



“INDUSTRIAL  
Division”  
Separated from  
December 2020

# SELECTED PROJECTS

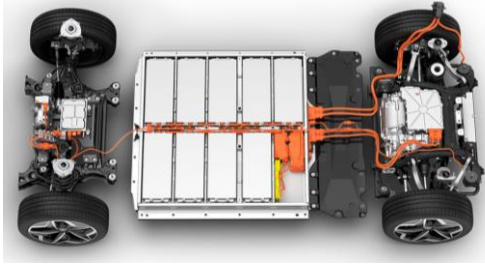

**VW**  
**Modules for MEB platform**  
(„Modularer E-Antriebs-Baukasten“)  
Components used in various models

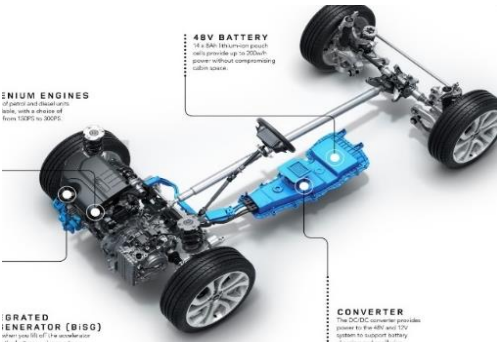

**Jaguar/Land Rover**  
**Mild Hybrid Battery box 48V**

POLYTEC replaced metal underbody shell (12 kg) by GMT/GMTex composite material and reduced weight down to less than 4 kg



**MAN**  
**Various cabin exterior parts**  
Production in 3 plants, more than 130 tools

**Daimler Mercedes**  
**Complex, multi-functional Underbody parts, global demands**  
Current production in Roosendaal (NL) and from summer 2021 additional on new production site in South Africa

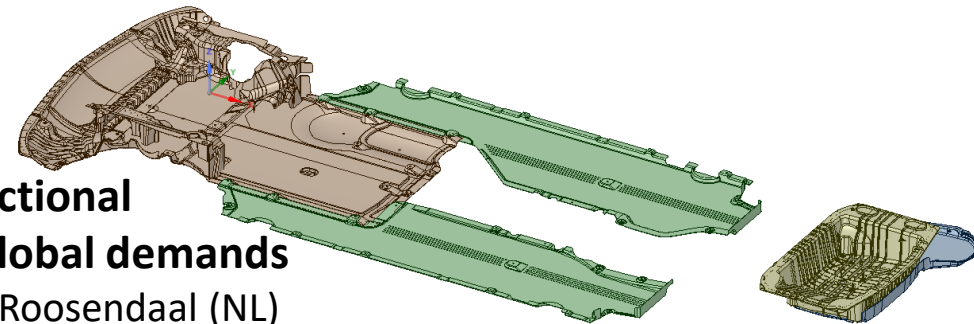

# STREAMS – OVERVIEW

- Sub projects of POLYTEC's digitation offensive
- Structuring of scope of applications

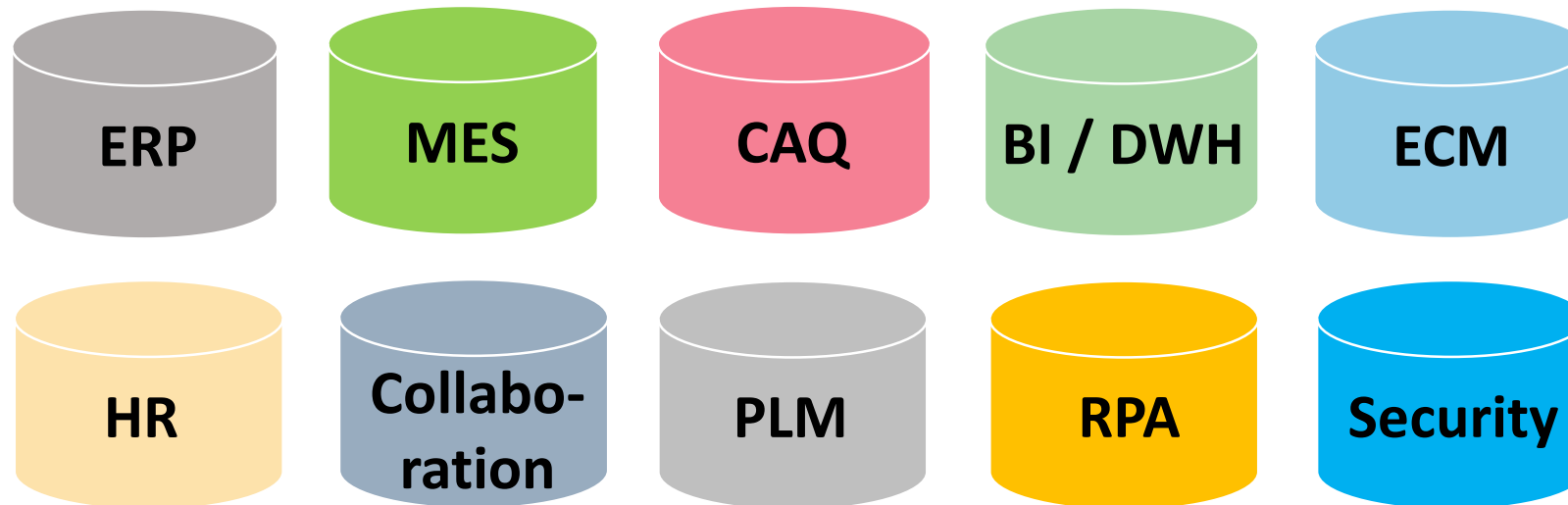

# INVESTING IN NEW PLANTS

## ■ Tianjin (PRC)



## ■ Telford (UK)



## ■ East London (RZA)



# SUSTAINABILITY: EBENSEE (AT) PLANT ALREADY CO<sub>2</sub> NEUTRAL



**A ROLE MODEL  
FOR THE  
POLYTEC GROUP:  
CLIMATE-NEUTRAL  
COOLING, HEATING  
AND PRODUCTION  
IN EBENSEE**

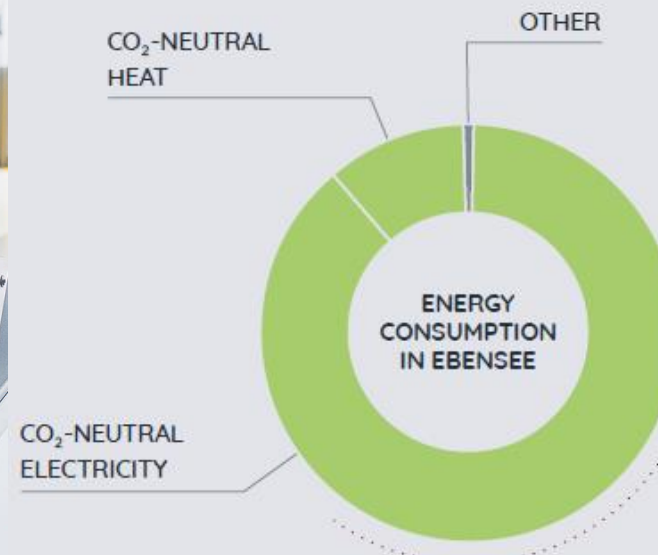



CLIENT

POLYTEC PLASTICS

POLYTEC COMPOSITES

POLYTEC CAR STYLING

FINANCIAL FIGURES Q3/Q1-Q3 2020

# SALES, EBIT MARGIN FY 2016-2019 – Q3 2020

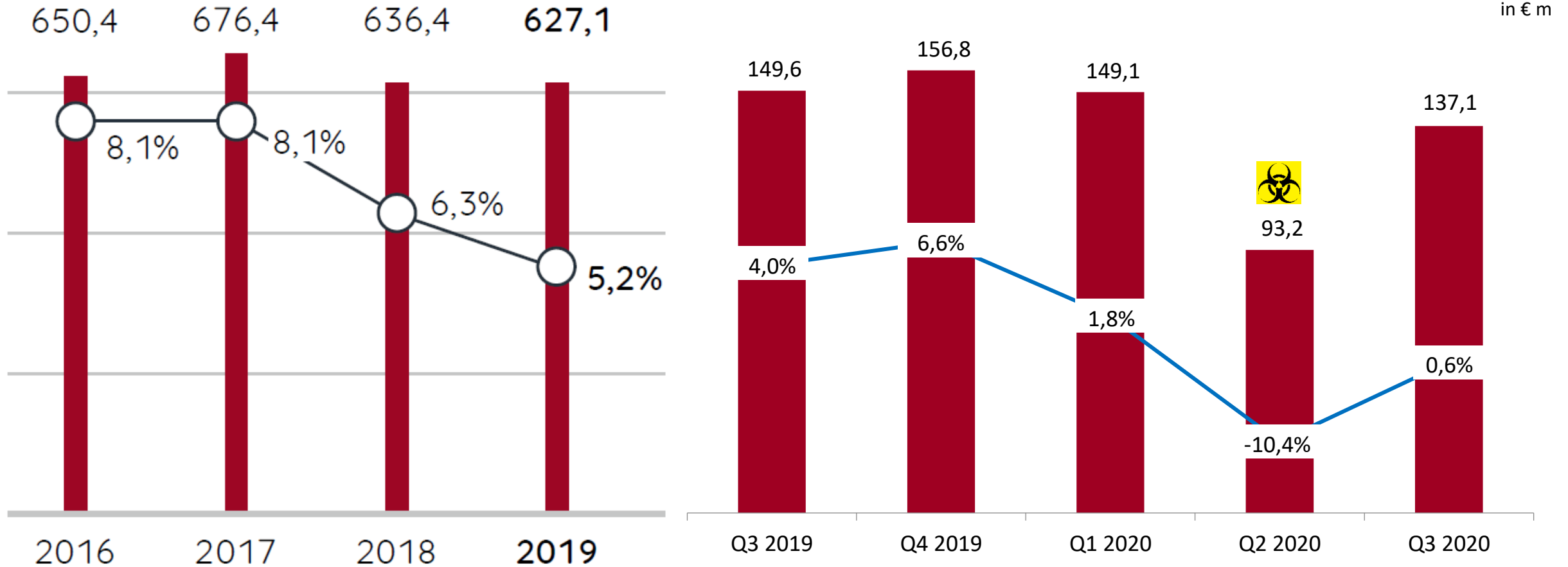

# EBITDA, EBITDA-MARGIN – QUARTARLY

in € mill.

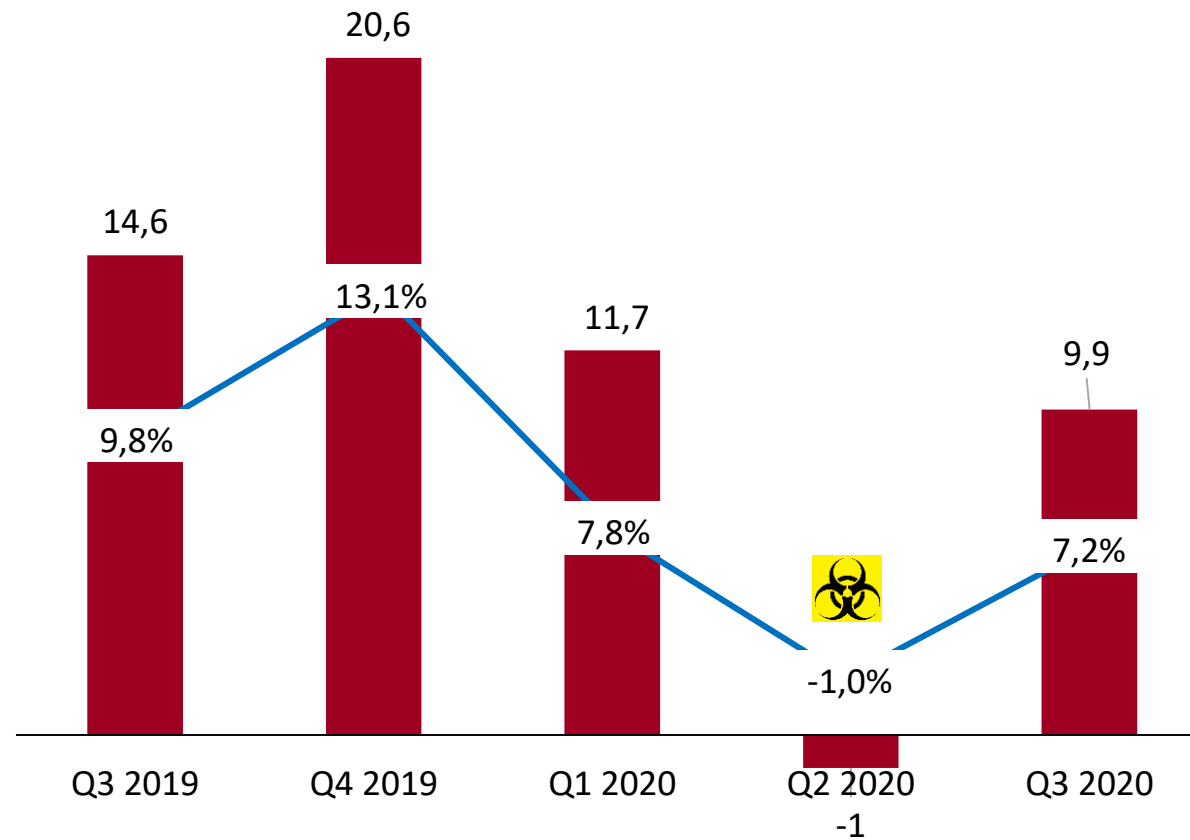



# EARNINGS – QUARTARLY

in € mill.  
EPS in €

## EARNINGS AFTER TAX

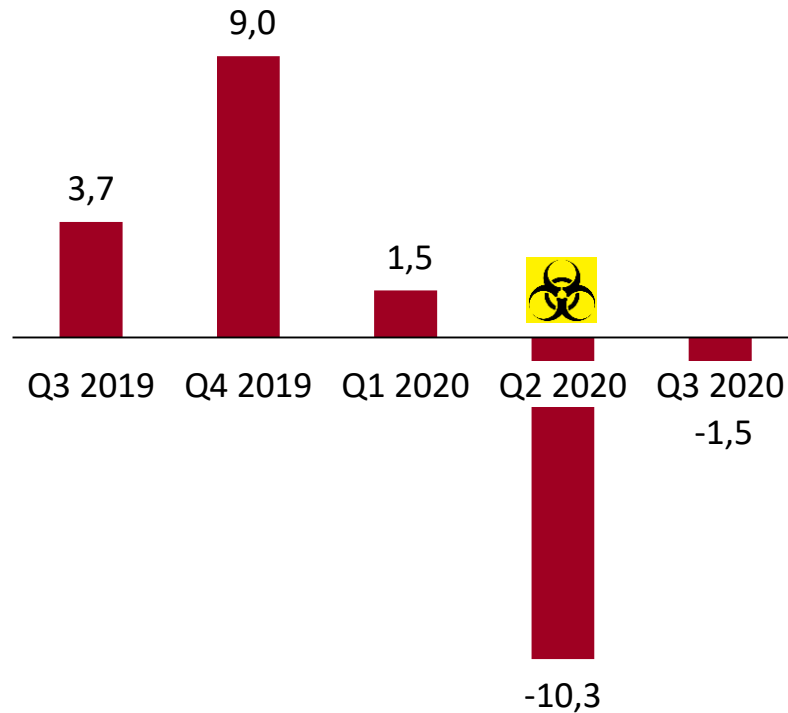

## EARNINGS PER SHARE

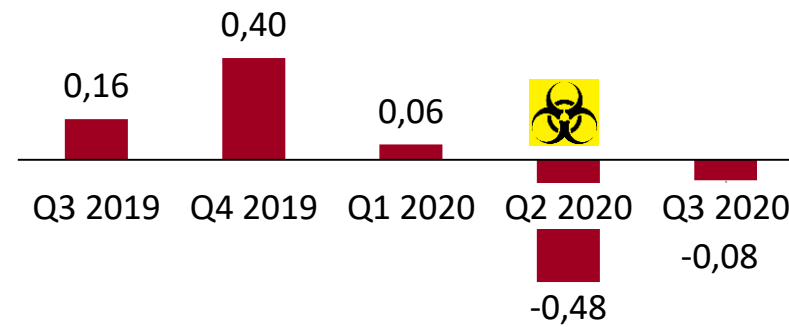

# EQUITY & EQUITY RATIO – QUARTARLY

in € mill.

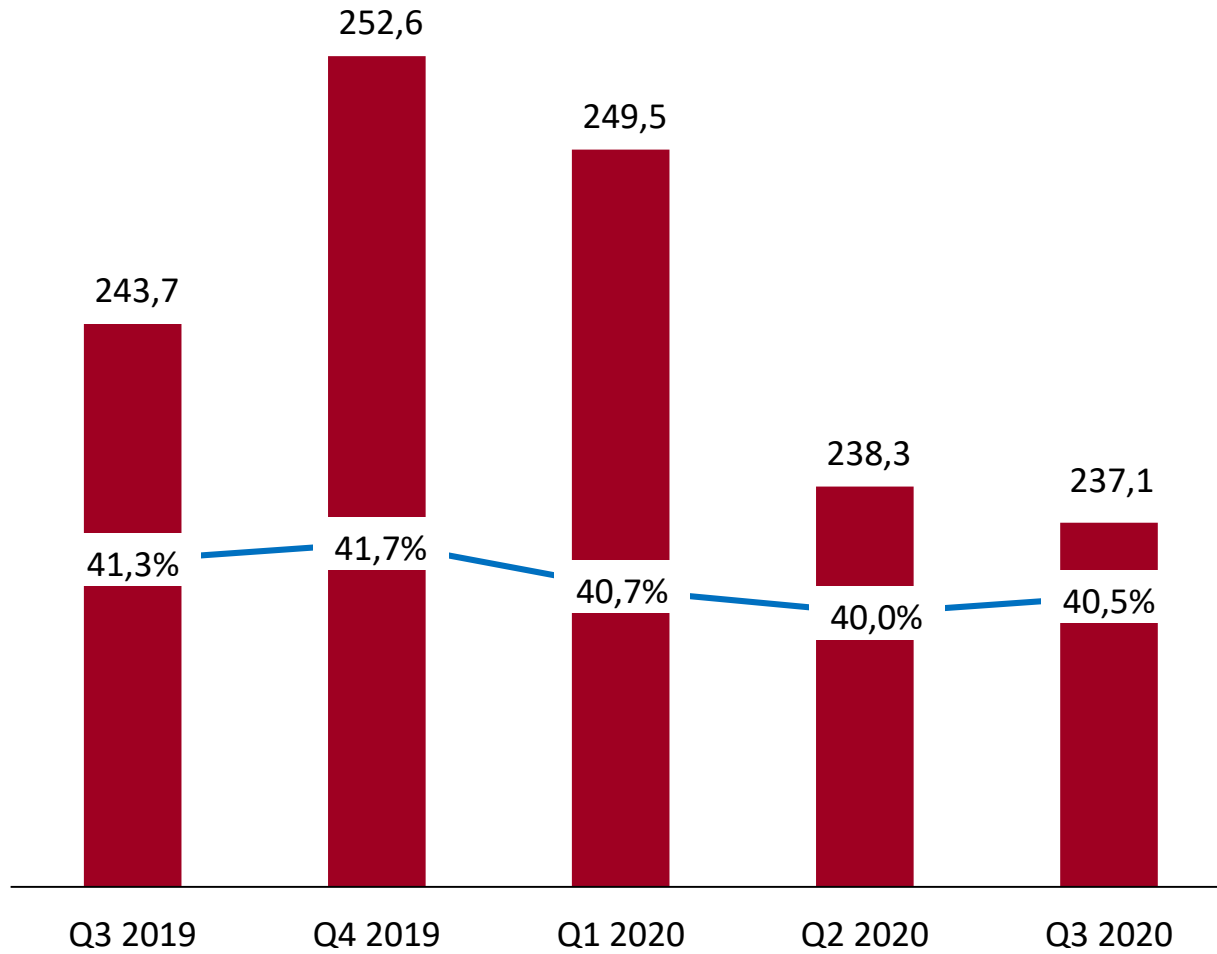

# NET DEBT, GEARING – QUARTARLY

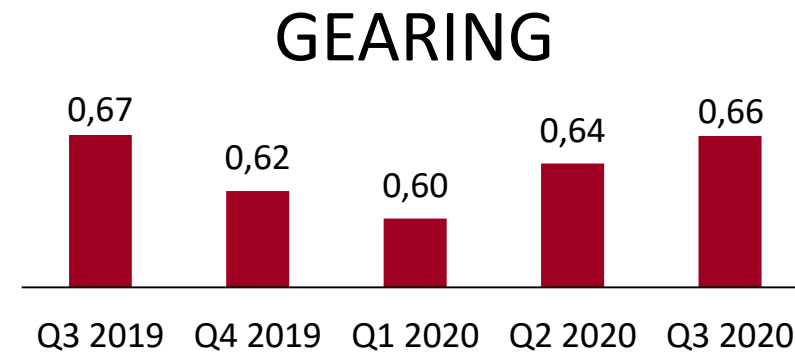
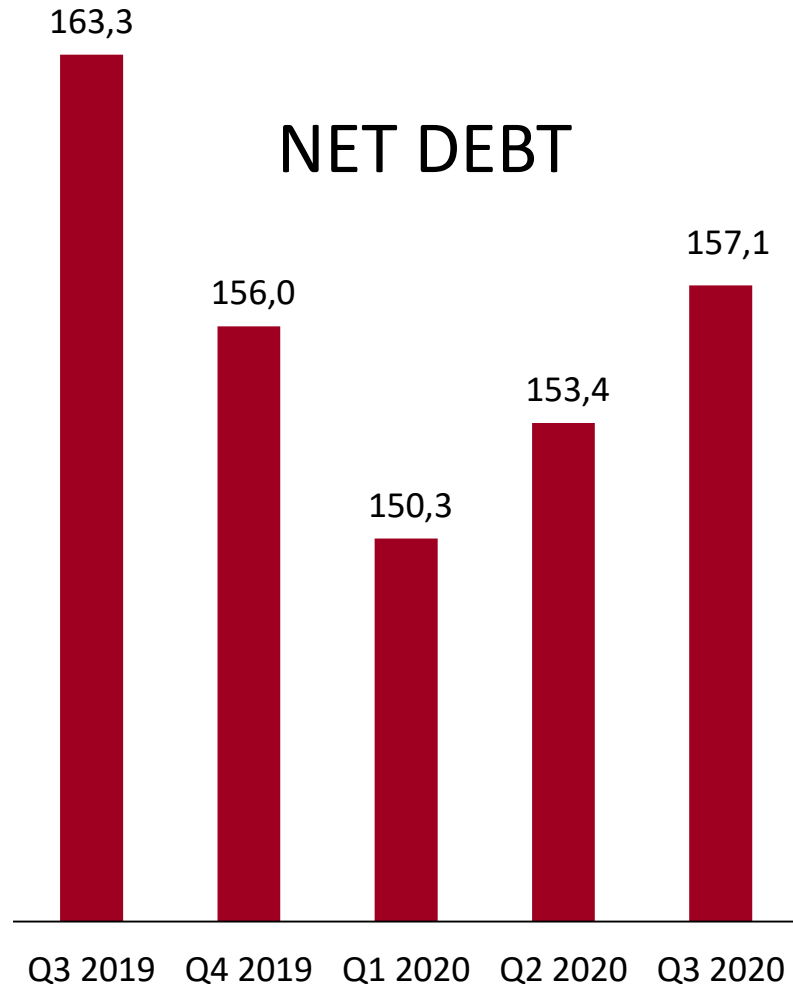

## OUTLOOK 2020 FINANCIAL YEAR

In view of the gradual improvement in the business trend since June 2020, the POLYTEC GROUP management remains cautiously optimistic with regard to the final quarter of the year and on the basis of the currently communicated call-offs, anticipates sales revenues of around EUR 520 million.

Earnings before interest and taxes (EBIT) will probably be balanced prior to special effects, which include the positive result of the sale of the participation in POLYTEC Industrial Plastics GmbH and possible negative impacts that in particular could result from countermeasures against the COVID-19 pandemic. Furthermore, the actual realisation of this result outlook depends upon the possible consequences of Brexit and other political and geopolitical events.

# CORPORATE CALENDAR 2021

Date	Day	Event
<b>22.04.2021</b>	THU	Financial statements and annual report FY 2020
<b>02.05.2021</b>	SUN	Record date „Annual General Meeting“
<b>07.05.2021</b>	FRI	Interim report Q1 2021
<b>12.05.2021</b>	WED	21st Annual General Meeting FY 2020, Hörsching, Austria, 10:00 a.m.
<b>18.05.2021</b>	TUE	Ex-dividend date
<b>19.05.2021</b>	WED	Record date „Dividends“
<b>20.05.2021</b>	THU	Dividend pay-out date
<b>12.08.2021</b>	THU	Half-year financial report 2021
<b>11.11.2021</b>	THU	Interim report Q3 2021

# SHARHOLDER STRUCTURE

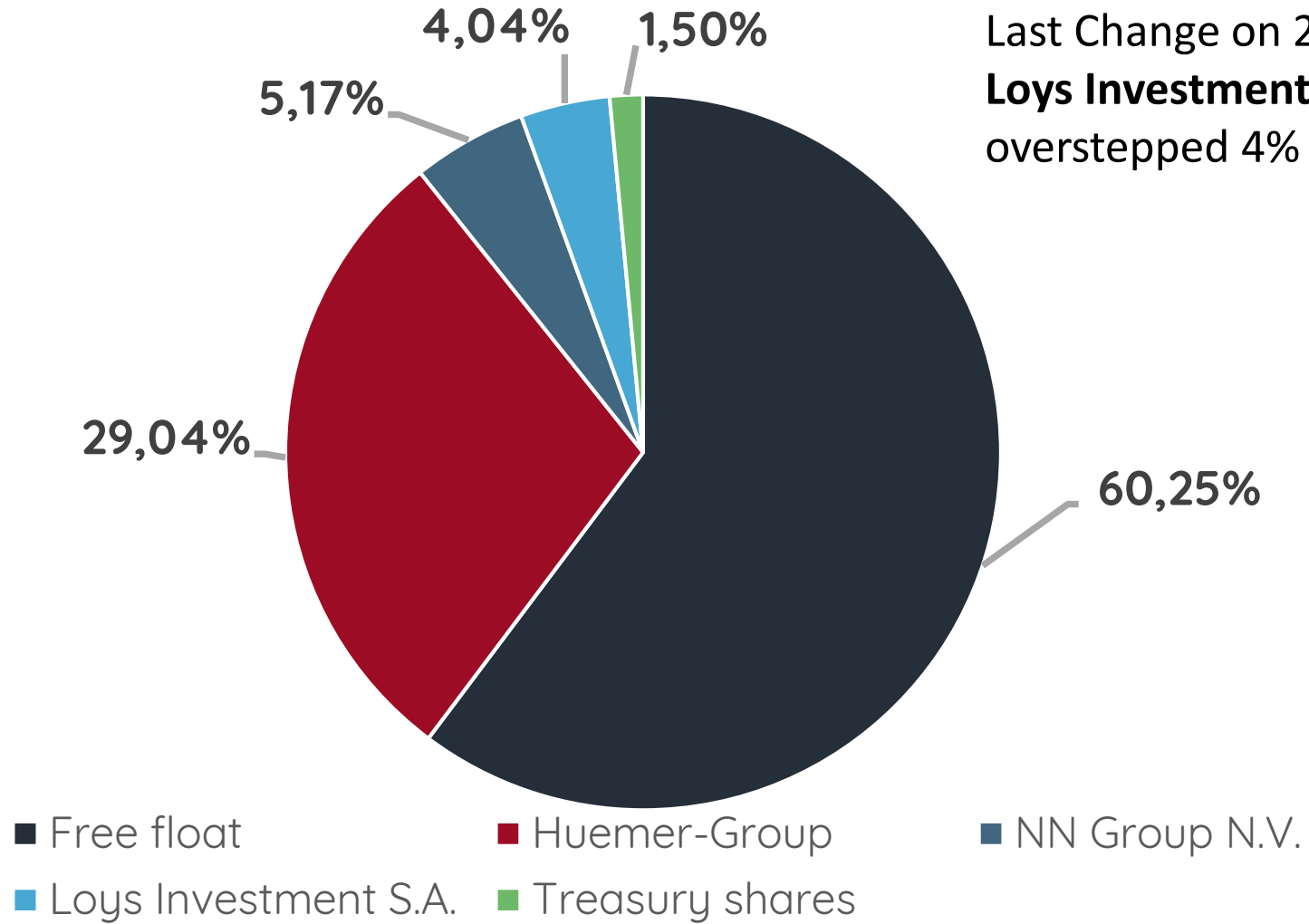

Last Change on 29 December 2020:  
**Loys Investment S.A.**  
overstepped 4% threshold

# NOTES



## CONTACT:

**POLYTEC Holding AG**

**Mr. Paul Rettenbacher – Investor Relations Manager**

E-Mail: [paul.rettentbacher@polytec-group.com](mailto:paul.rettentbacher@polytec-group.com)

PASSION CREATES INNOVATION

[www.polytec-group.com/en/investor-relations/news](http://www.polytec-group.com/en/investor-relations/news)

